

Contents:

Lock Assembly
Instructions
Wire Ties
Warranty Card

Tools Required:

T-30 Torx
8 and 10 mm Socket
Small and large Phillips
Screwdriver
Knife

Tech Support:

Call 1-800-342-5911
or 1-905 734 7111

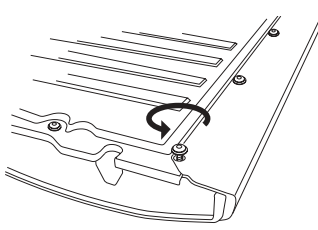

1.
Unscrew the 15 access panel screws and remove panel

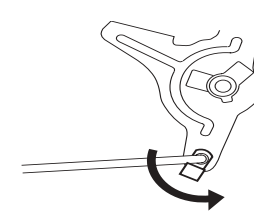

2.
Pry plastic rod retainer off using a screw driver and remove rod.

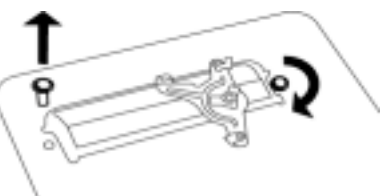

3.
Unscrew the two Hex Bolts that mount the handle using a 10MM socket.

Set the Handle and the Hex Bolts aside.



4.
Turn the Handle over and slip a knife blade between the Gasket and the Handle and pop the gasket off the pins holding it to the Handle.

Set the Gasket aside.

NOTE: Skip steps 5-7 and 9 if your truck has no Backup Camera.

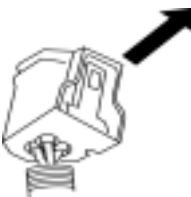

5.
Disconnect the Wire Harness from the Camera. The connector will release by prying and slightly bending the central catch up.

Be carefull not to overbend and snap off the catch.

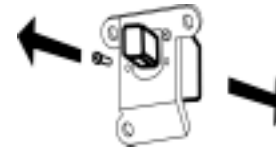

6.
Remove the Camera Mounting Bracket by loosening the two mounting bolts and remove the Camera from the Mounting Bracket by loosening the two small Phillips Head Screws.



7.
Remove the Pop&Lock Cover from its Bracket by loosening the two small Phillips Head Screws, then remove the Bracket itself from the Pop&Lock Handle by loosening the two big Phillips Head Screws with a 8MM Socket.

Mount the Camera to the Pop&Lock Bracket and re-attach it wit the two big Phillips Head Screws

8.
Attach the Gasket to the Pop&Lock Handle and mount the Pop&Lock Handle into the tailgate with the 6MM Hex Bolts.

Re-attach the rods to the plastic rod retainers and re-attach the access panel.

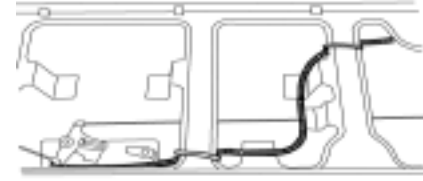

9.
Reroute the cable as shown and attaching it to the vertical pillars with two wire ties such that the cable doesn't interfere with the lock mechanism. Connect the camera.

This completes the Pop&Lock installation.

LIMITED WARRANTY TERMS AND CONDITIONS

1. **INSTALLATION:** Pop & Lock™ is not responsible for installing the Pop & Lock™ or for the harm suffered by any person as a result of installing it.

2. **WARRANTIES:**

- a) Customer acknowledges that it is unreasonable to believe that any device whatever will prevent a theft in the case of every attempt and that the most that can be expected from a so-called anti-theft or security device is that it will deter many thieves.
- b) **POP & LOCK™ MAKES, AND THE CUSTOMER RECEIVES, NO WARRANTY, EXPRESSED OR IMPLIED, EXCEPT THE WARRANTIES OF TITLE TO THE POP & LOCK™ AND THEIR MERCHANTABILITY, PARTICULARLY NO WARRANTY OF FITNESS FOR A PARTICULAR USE OR PURPOSE OR AGAINST INFRINGEMENT.**
- c) As Customer's only remedy, Pop & Lock™ will repair or replace, at its option and without charge, any lock that is defective in material or workmanship when received by the Customer and is returned to Pop & Lock™, FOB Pop & Lock's offices, within one (1) year after its receipt by the Customer. Pop & Lock™ will ship all replacement, or repaired locks to the Customer, FOB Pop & Lock's shipping point.

3. **NO LIABILITY:** Pop & Lock™ is not liable for any loss or damage claimed by the Customer or any third person to have been suffered or incurred, as a result of, or related to, the locks purchased under this agreement, regardless of the circumstances or form of action, except any bodily injury or death for which Pop & Lock™ is liable under products-liability law. Without limited the generality of the foregoing, in no event will Pop & Lock™ be liable to the Customer for any indirect, special, or consequential damages, regardless of the circumstances or the cause of action, particularly not for the value of the vehicle, or any other money damages in the event that a tailgate is stolen either notwithstanding the use of a Pop & Lock™ or when it has been returned for repair or replacement.

For Technical Support call 800-342-5911 8:00am to 4:30pm Monday to Friday EST.